

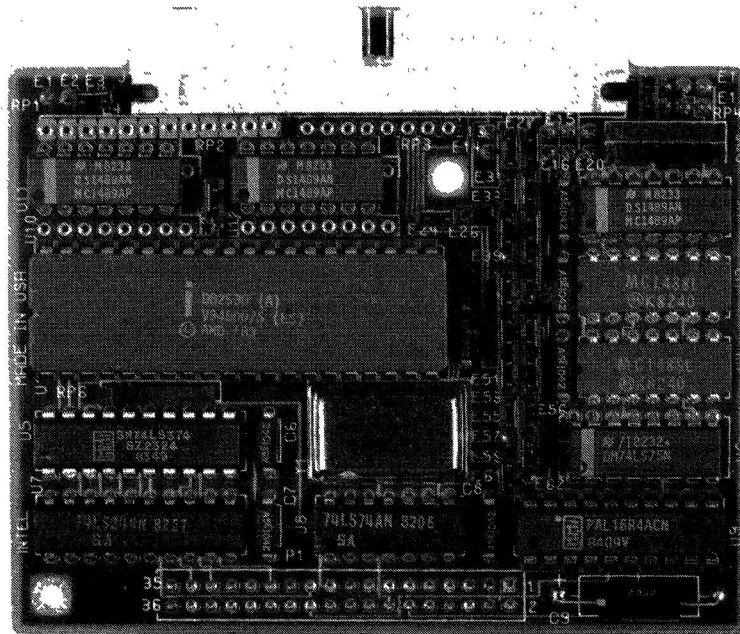

## ISBX™ 354 DUAL CHANNEL SERIAL I/O MULTIMODULE™ BOARD

- Two RS232C or RS422A/449 Programmable Synchronous/Asynchronous Communications Channels
- Programmable Baud Rate Generation for Each Channel
- Full Duplex Operation
- ISBX™ Bus Compatible I/O Expansion
- Supports HDLC/SDLC, NRZ, NRZI or FM Encoding/Decoding
- Three Interrupt Options for Each Channel
- Low Power Requirements

The Intel iSBX 354 Serial I/O MULTIMODULE board is a member of Intel's line of iSBX compatible MULTIMODULE products. The iSBX MULTIMODULE board plugs directly into any iSBX bus compatible host board offering incremental on-board I/O expansion. Utilizing Intel's 82530 Serial Communications Controller component, the iSBX 354 module provides two RS232C or RS422A/449 programmable synchronous/asynchronous communications channels. The 82530 component provides two independent full duplex serial channels, on chip crystal oscillator, baud-rate generator and digital phase locked loop capability for each channel. The iSBX board connects to the host board through the iSBX bus. This offers maximum on-board performance and frees the MULTIBUS® System bus for use by other system resources.



280045-1

**FUNCTIONAL DESCRIPTION**

**Communications Interface**

The iSBX 354 module uses the Intel 82530 Serial Communications Controller (SCC) component providing two independent full duplex serial channels. The 82530 is a multi-protocol data communications peripheral designed to interface high speed communications lines using Asynchronous, Byte-Synchronous and Bit-Synchronous protocols to Intel's micro-processor based board and system level products. The mode of operation (i.e. asynchronous or synchronous), data format, control character format, and baud-rate generation are all under program control. The 82530 SCC component can generate and check CRC codes in any Synchronous mode and can be programmed to check data integrity in various modes. The command lines, serial data lines, and signal ground lines are brought out to a double edge connector.

The iSBX 354 module provides a low cost means to add two serial channels to iSBC® boards with 8 or 16 bit MULTIMODULE interfaces. In the factory default configuration, the iSBX 354 module will support two RS232C interfaces. With user supplied drivers and termination resistors, the iSBX 354 module can be reconfigured to support RS422A/449 communication interfaces with support on Channel A only for multidrop control from the base board. Both channels can be configured as DTE or DCE with RS232C interfaces.

**Interrupt Request Line**

The 82530 SCC component provides one interrupt to the MINTRO signal of the iSBX interface. There are six sources of interrupts in the SCC component (Transmit, Receive and External/Status interrupts in both channels). Each type of interrupt is enabled under program control with Channel A having higher priority than Channel B, and with Receive, Transmit

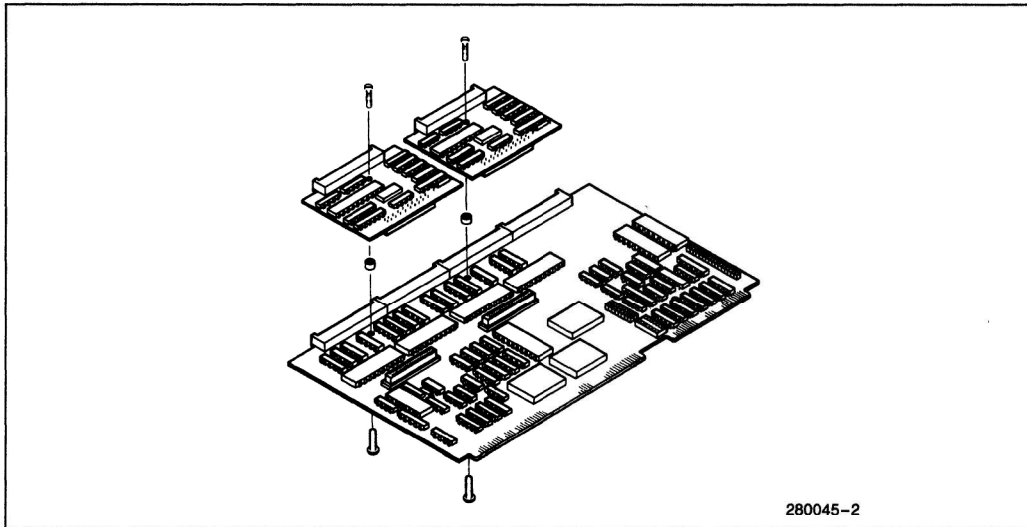

Figure 1. Installation of 2 ISBX™ 354 MULTIMODULE™ Boards on an iSBC® Board

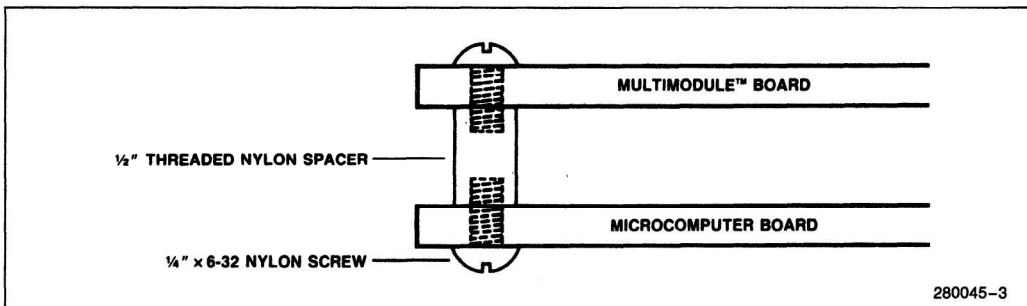

Figure 2. Mounting Technique



## ISBX™ 354 MODULE

and External/Status interrupts prioritized in that order within each channel.

the ISBX 354 MULTIMODULE board on a Host Board. Figures 3 and 4 provide cabling diagrams.

### Installation

The ISBX 354 module plugs directly into the female ISBX connector on the host board. The module is then secured at one additional point with nylon hardware to insure the mechanical security of the assembly. Figures 1 and 2 demonstrate the installation of

### Programming Considerations

The Intel 82530 SCC component contains several registers that must be programmed to initialize and control the two channels. Intel's ISBX 354 Module Hardware Reference Manual (Order # 146531-001) describes these registers in detail.

#### RS232C DB-25 CONNECTORS

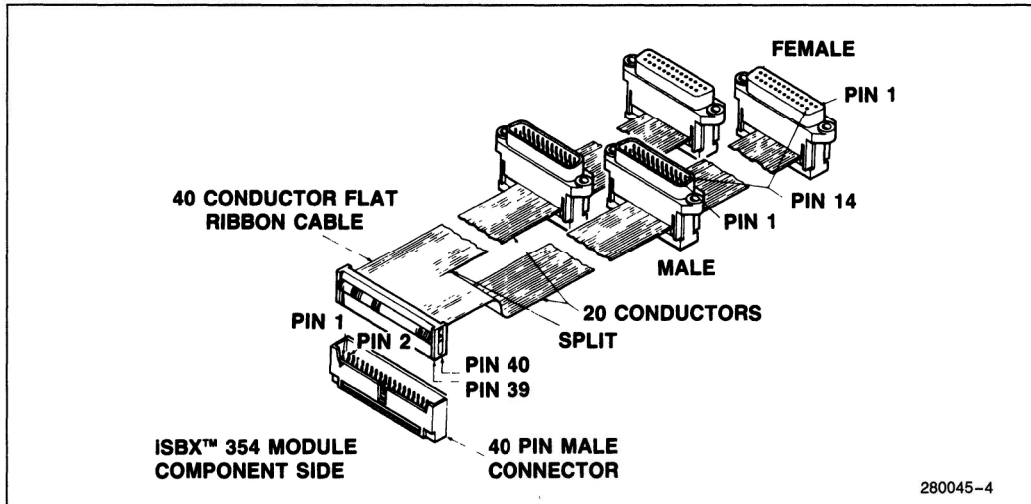

Figure 3. RS232C Cable Construction

#### RS422A/449 DB-37 CONNECTORS

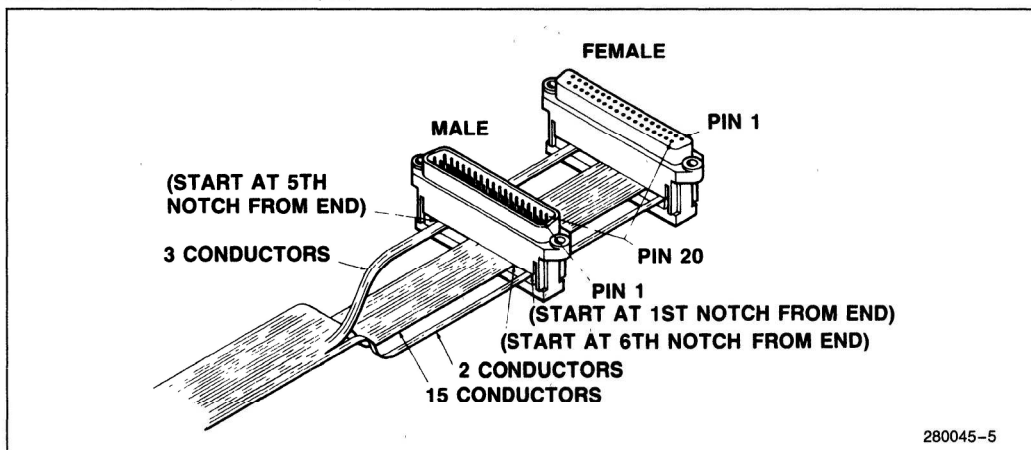

Figure 4. RS422A/449 Cable Construction



### SPECIFICATIONS

#### Word Size

Data—8 bits

#### Clock Frequency

4.9152 MHz

#### Serial Communications

**Synchronous**—Internal or external character synchronization on one or two synchronous characters

**Asynchronous**—5–8 bits and 1, 1½ or 2 stop bits per character; programmable clock factor; break detection and generation; parity, overrun, and framing error detection

#### Sample Baud Rate:

Synchronous X1 Clock	
Baud Rate	82530 Count Value (Decimal)
64000	36
48000	49
19200	126
9600	254
4800	510
2400	1022
1800	1363
1200	2046
300	8190
Asynchronous X16 Clock	
Baud Rate	82530 Count Value (Decimal)
19200	6
9600	14
4800	30
2400	62
1800	83
1200	126
300	510
110	1394

### INTERFACES

**iSBX™ Bus:** Meets the iSBX Specification, Compliance Level: D8 F

**Serial:** Meets the EIA RS232C standard on Channels A and B. Meets the EIA RS422A/449 standard on Channels A and B, Multi-drop capability on Channel A only.

### Signals Provided

#### RS232C DTE

- Transmit Data
- Receive Data
- Request to Send
- Clear to Send
- Data Set Ready
- Signal Ground
- Carrier Detect
- Transmit Clock (2)
- Receive Clock
- Data Terminal Ready
- Ring Indicator

#### RS232C DCE

- Transmit Data
- Receive Data
- Clear to Send
- Data Set Ready
- Signal Ground
- Carrier Detect
- Transmit Clock (2)
- Receive Clock
- Ring Indicator

#### RS422A/449

- Send Data
- Receive Timing
- Receive Data
- Terminal Timing
- Receive Common

#### I/O Port Addresses

Port Address		Function
8-Bit	16-Bit	
X0		Read Status Channel B Write Command Channel B
X2		Read Data Channel B Write Data Channel B
X4		Read Status Channel A Write Command Channel A
X6		Read Data Channel A Write Data Channel A
Y0		Read Disable RS422A/449 Buffer Write Enable RS422A/449 Buffer

#### NOTES:

1. The "X" and "Y" values depend on the address of the iSBX interface as viewed by the base board.
2. "X" corresponds with Activation of the MCS0/interface signal; "Y" corresponds with Activation of the MCS1/interface signal.

### Power Requirements

- + 5V at 0.5A
- + 12V at 50 mA
- 12V at 50 mA

### Physical Characteristics

- Width: 2.85 inches
- Length: 3.70 inches
- Height: 0.8 inches
- Weight: 85 grams



**ENVIRONMENTAL  
CHARACTERISTICS**

Temperature: 0°C to 55°C operating at 200 linear feet per minute across baseboard and MULTIMODULE board

Humidity: To 90%, without condensation

**REFERENCE MANUAL**

146531-001—iSBX 354 Channel Serial I/O Board Hardware Reference Manual

Reference manuals may be ordered from any Intel sales representative, distributor office, or from Intel Literature Department, 3065 Bowers Avenue, Santa Clara, CA 95051.

**ORDERING INFORMATION**

**Part Number Description**

ISBX 354 Dual Channel I/O MULTIMODULE